

GBRU/GBNA Preventive Maintenance Manual



This document is prevention maintenance manual for the GBRU/GBNA.

1. Application Model

Item	Description	Fujitsu P/N
1	Pre-Acceptor	KD02169-D9x1 KD02169-D8x1
2	Upper Module	KD02160-D6xx KD02160-D5xx KD02160-D4xx
3	Lower Module	KD02165-D8xx KD02165-D7xx KD02165-D6xx
4	Cassette	KD02155-D9x1 KD02155-D8xx KD02155-D0xx

NOTE: Including other all FRU

2. Maintenance tools

Item	Description	Note
1	Waste or cloth	not dirty
2	Ethanol solvent or Isopropyl Alcohol	
3	Cotton swab	
4	Blower or Soft brush	
5	Spatula or scraper	

					TITLE Preventive Maintenance Manual	
					DRAW. NO. P3KD02160-0002	
					CUST	
02	2008.02.25	M.NAKAO	K.KITANO	Y.KATOH	Item2 of maintenance tools changed	
EDIT	DATE	DESIG.	CHECK	APPR.	DESCRIPTION	
DESIG.	2008.02.25	M.NAKAO	CHECK	K.KITANO	APPR.	Y.KATOH
FUJITSU FRONTECH LIMITED						1 / 31

3. Maintenance Item

- 3-1) Cleaning
- 3-2) Adjusting
- 3-3) Lubrication
- 3-4) Changing

4. Recommended cycle for preventive maintenance

Average number of note/day	Average number of note/month	PM period (Months)
1,000	30,000	5
2,000	60,000	
3,000	90,000	3
4,000	120,000	
5,000	150,000	
6,000	180,000	
7,000	210,000	2
8,000	240,000	
9,000	270,000	
10,000	300,000	

						TITLE Preventive Maintenance Manual	
						DRAW. NO. P3KD02160-0002	
						CUST	
02	2008.02.25	M.NAKAO	K.KITANO	Y.KATOH	Item2 of maintenance tools changed		
EDIT	DATE	DESIG.	CHECK	APPR.	DESCRIPTION		
DESIG.	2008.02.25	M.NAKAO	CHECK	K.KITANO	APPR.	Y.KATOH	FUJITSU FRONTECH LIMITED
							2 / 31

5. Parts

5-1) Sensor

Item	Description	Maintenance	Period	Time	Detail
1	Sensor (PAC)	Cleaning	Sensor status [Clean soon]	5 min	PM-SEN-010
2	Sensor (UPT)	Cleaning	Sensor status [Clean soon]	3 min	PM-SEN-020
3	Sensor (ESC)	Cleaning	Sensor status [Clean soon]	3 min	PM-SEN-030
4	Sensor (BV)	Cleaning	Sensor status [Clean soon]	3 min	P3KD02136-A002 (another document)
5					
6					
7					
8					

					TITLE Preventive Maintenance Manual	
					DRAW. NO. P3KD02160-0002	
					CUST	
02	2008.02.25	M.NAKAO	K.KITANO	Y.KATOH	Item2 of maintenance tools changed	
EDIT	DATE	DESIG.	CHECK	APPR.	DESCRIPTION	
DESIG.	2008.02.25	M.NAKAO	CHECK	K.KITANO	APPR.	Y.KATOH
FUJITSU FRONTECH LIMITED						3 / 31

5-2) Belt

Item	Description	Maintenance	Period	Time	Detail
1	Belt (PAC)	Cleaning	Sensor status [Clean soon]	5 min	PM-BLT-010
2	Flat belt (SEP/BV-Ent)	Cleaning	Sensor status [Clean soon]	5 min	PM-BLT-020
3	Flat belt (UPT)	Cleaning	Sensor status [Clean soon]	5 min	PM-BLT-030
4	Flat belt (ESC)	Cleaning	Sensor status [Clean soon]	5 min	PM-BLT-040
5	Flat belt (LWT)	Cleaning	Sensor status [Clean soon]	5 min	PM-BLT-050
6					
7					
8					

Note : Do not come off the belts.

					TITLE Preventive Maintenance Manual	
					DRAW. NO. P3KD02160-0002	
					CUST	
02	2008.02.25	M.NAKAO	K.KITANO	Y.KATOH	Item2 of maintenance tools changed	
EDIT	DATE	DESIG.	CHECK	APPR.	DESCRIPTION	
DESIG.	2008.02.25	M.NAKAO	CHECK	K.KITANO	APPR.	Y.KATOH
FUJITSU FRONTECH LIMITED						4 / 31

5-3) Roller

Item	Description	Maintenance	Period	Time	Detail
1	Roller (SEP/BV-Ent)	Cleaning	Sensor status [Clean soon]	10 min	PM-RLL-010
2	Roller (UPT)	Cleaning	Sensor status [Clean soon]	5 min	PM-RLL-020
3	Roller (ESC)	Cleaning	Sensor status [Clean soon]	5 min	PM-RLL-030
4	Roller (LWT)	Cleaning	Sensor status [Clean soon]	5 min	PM-RLL-040
5	Roller (CAS)	Cleaning	Sensor status [Clean soon]	5 min	PM-RLL-050
6	Roller (BV)	Cleaning	Sensor status [Clean soon]	15 min	P3KD02136-A001 (another document)
7					
8					

					TITLE Preventive Maintenance Manual	
					DRAW. NO. P3KD02160-0002	
					CUST	
02	2008.02.25	M.NAKAO	K.KITANO	Y.KATOH	Item2 of maintenance tools changed	
EDIT	DATE	DESIG.	CHECK	APPR.	DESCRIPTION	
DESIG.	2008.02.25	M.NAKAO	CHECK	K.KITANO	APPR.	Y.KATOH
FUJITSU FRONTECH LIMITED						5 / 31

5-4) Other

Item	Description	Maintenance	Period	Time	Detail
1	Guide (BV)	Cleaning	Sensor status [Clean soon]	2 min	P3KD02136-A001 (another document)

						TITLE Preventive Maintenance Manual	
						DRAW. NO. P3KD02160-0002	CUST
02	2008.02.25	M.NAKAO	K.KITANO	Y.KATOH	Item2 of maintenance tools changed		
EDIT	DATE	DESIG.	CHECK	APPR.	DESCRIPTION		
DESIG.	2008.02.25	M.NAKAO	CHECK	K.KITANO	APPR.	Y.KATOH	FUJITSU FRONTECH LIMITED SHEET 6 / 31

PM-SEN-010

Sensor Cleaning(PAC)

Cleaning procedure

1. Wipe and clean the whole surface on the sensors with a waste cloth or cotton swab.

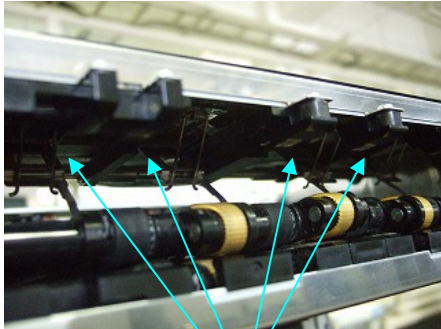
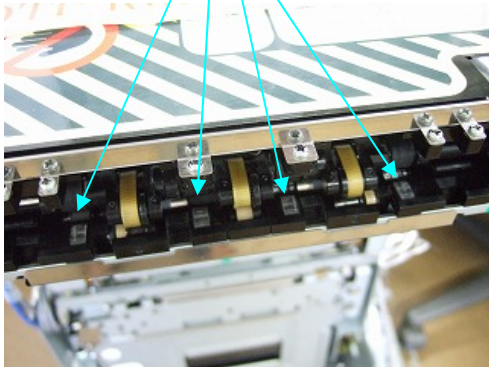
Sensor name	Tool	Detail	Remark
PS1S PS2S PS3S PS4S	Waste or Cotton swab	 <p>Up side</p>  <p>Down side</p>	

					TITLE Preventive Maintenance Manual	
					DRAW. NO. P3KD02160-0002	
					CUST	
02	2008.02.25	M.NAKAO	K.KITANO	Y.KATOH	Item2 of maintenance tools changed	
EDIT	DATE	DESIG.	CHECK	APPR.	DESCRIPTION	
DESIG.	2008.02.25	M.NAKAO	CHECK	K.KITANO	APPR.	Y.KATOH
FUJITSU FRONTECH LIMITED						8 / 31

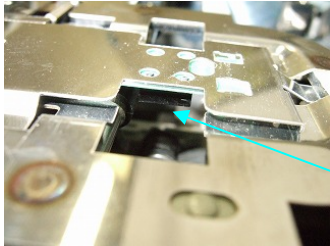
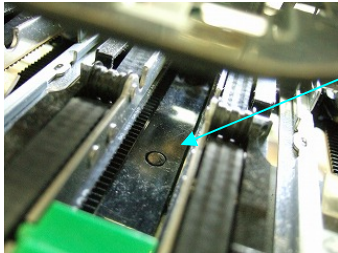
Sensor name	Tool	Detail	Remark
PTCS	Waste or Cotton swab	 <p>Up side</p>  <p>Down side</p>	
PASS	Waste or Cotton swab	 <p>Up side</p>  <p>Down side</p>	

						TITLE Preventive Maintenance Manual	
						DRAW. NO. P3KD02160-0002	
						CUST	
02	2008.02.25	M.NAKAO	K.KITANO	Y.KATOH	Item2 of maintenance tools changed		
EDIT	DATE	DESIG.	CHECK	APPR.	DESCRIPTION		
DESIG.	2008.02.25	M.NAKAO	CHECK	K.KITANO	APPR.	Y.KATOH	FUJITSU FRONTECH LIMITED <small>SHEET</small> 9 / 31

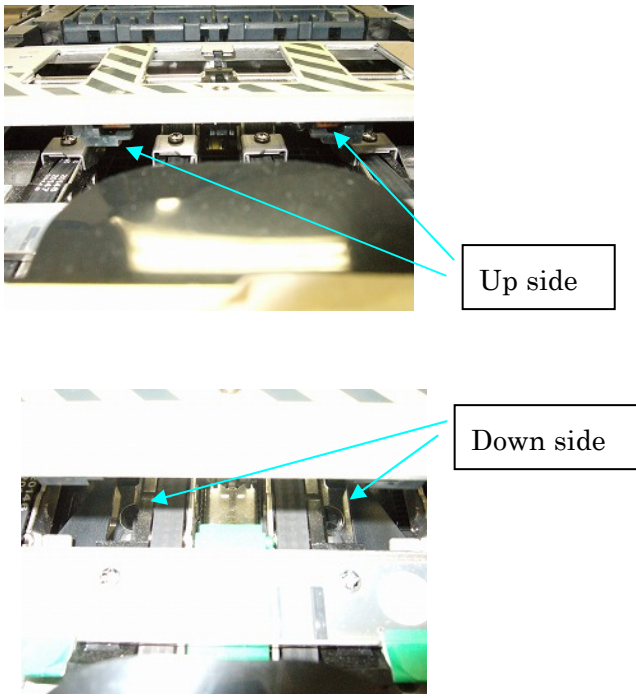
Sensor name	Tool	Detail	Remark
PDSS	Waste or Cotton swab	 <p>Up side</p> <p>Down side</p>	

						TITLE Preventive Maintenance Manual	
						DRAW. NO. P3KD02160-0002	
						CUST	
02	2008.02.25	M.NAKAO	K.KITANO	Y.KATOH	Item2 of maintenance tools changed		
EDIT	DATE	DESIG.	CHECK	APPR.	DESCRIPTION		
DESIG.	2008.02.25	M.NAKAO	CHECK	K.KITANO	APPR.	Y.KATOH	FUJITSU FRONTECH LIMITED SHEET 10 / 31

PM-SEN-020

Sensor Cleaning(UPT)

Cleaning procedure

1. Wipe and clean the whole surface on the sensors with a cotton swab or blower.

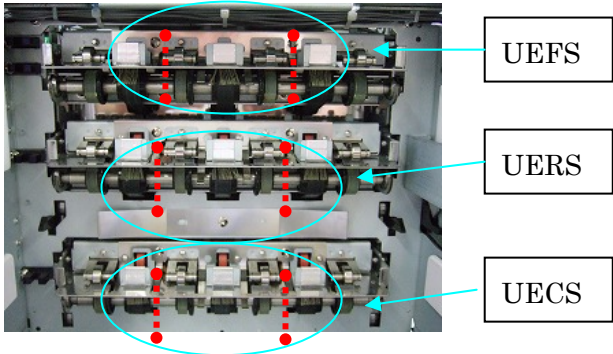
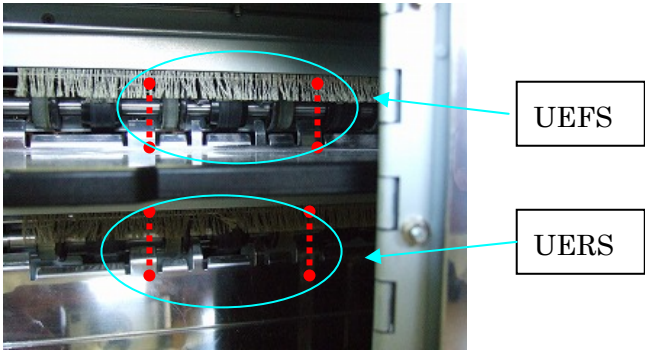
Sensor name	Tool	Detail	Remark
UEFS UERS UECS	Cotton swab or Blower.	<div style="border: 1px solid black; padding: 5px; width: fit-content; margin-bottom: 10px;">Removable type</div>  <div style="border: 1px solid black; padding: 5px; width: fit-content; margin-top: 10px;">Fix type</div> 	

						TITLE Preventive Maintenance Manual	
						DRAW. NO. P3KD02160-0002	
						CUST	
02	2008.02.25	M.NAKAO	K.KITANO	Y.KATOH	Item2 of maintenance tools changed		
EDIT	DATE	DESIG.	CHECK	APPR.	DESCRIPTION		
DESIG.	2008.02.25	M.NAKAO	CHECK	K.KITANO	APPR.	Y.KATOH	FUJITSU FRONTECH LIMITED SHEET 11 / 31

PM-SEN-030

Sensor Cleaning(ESC)

Cleaning procedure

1. Wipe and clean the whole surface on the sensors with a waste cloth or cotton swab.

Sensor name	Tool	Detail	Remark
EECS	Waste or Cotton swab		

						TITLE Preventive Maintenance Manual	
						DRAW. NO. P3KD02160-0002	
						CUST	
02	2008.02.25	M.NAKAO	K.KITANO	Y.KATOH	Item2 of maintenance tools changed		
EDIT	DATE	DESIG.	CHECK	APPR.	DESCRIPTION		
DESIG.	2008.02.25	M.NAKAO	CHECK	K.KITANO	APPR.	Y.KATOH	FUJITSU FRONTECH LIMITED
							12 / 31

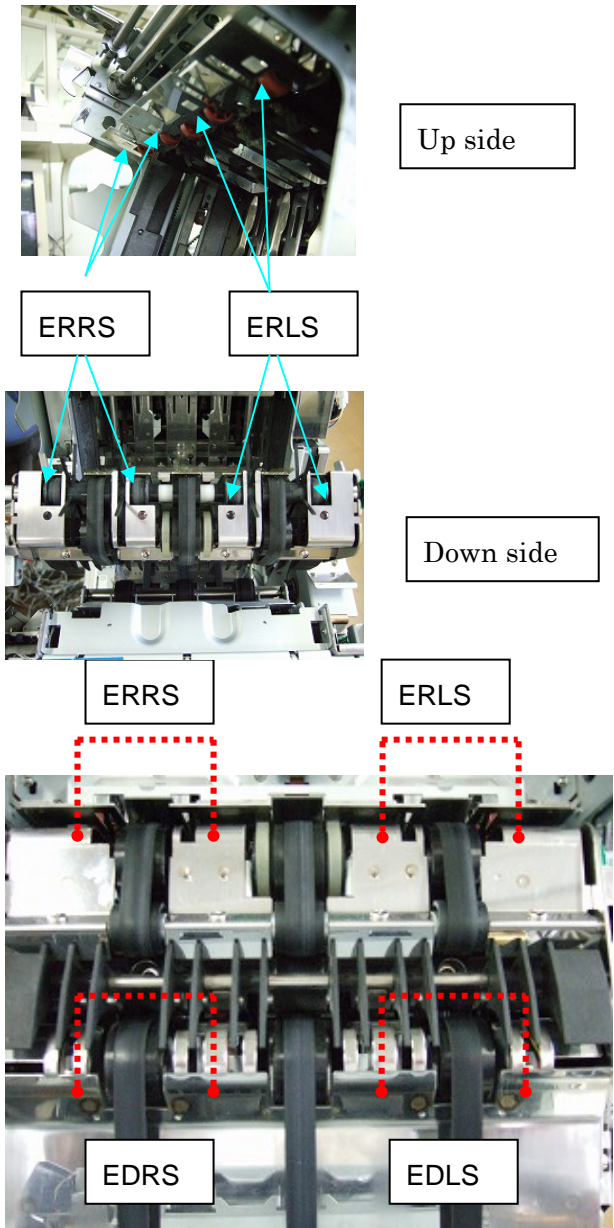
Sensor name	Tool	Detail	Remark
ERLS ERRS EDLS EDRS	Waste or Cotton swab		

					TITLE Preventive Maintenance Manual	
					DRAW. NO. P3KD02160-0002	
					CUST	
02	2008.02.25	M.NAKAO	K.KITANO	Y.KATOH	Item2 of maintenance tools changed	
EDIT	DATE	DESIG.	CHECK	APPR.	DESCRIPTION	
DESIG.	2008.02.25	M.NAKAO	CHECK	K.KITANO	APPR.	Y.KATOH
FUJITSU FRONTTECH LIMITED						SHEET 13 / 31

PM-BEL-010

Belt Cleaning(PAC)

Cleaning procedure

1. Wipe and clean the whole surface on the belts with a waste cloth which applied solvent by rotating the manual knob.

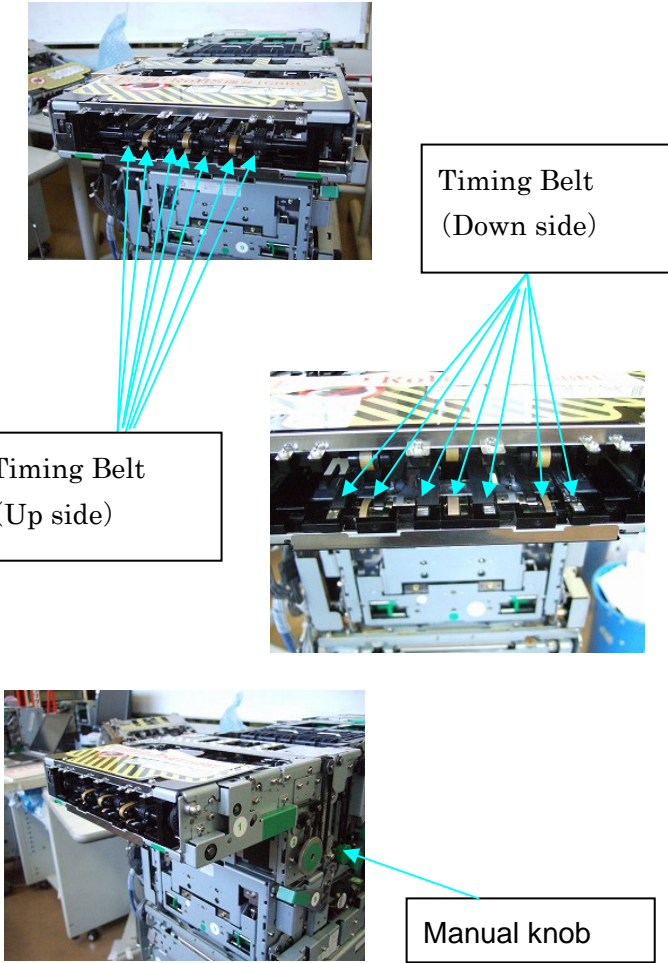
Point	Tool	Detail	Remark
Timing Belt (PAC)	Waste Ethanol solvent Or Isopropyl Alcohol	 <p>Timing Belt (Down side)</p> <p>Timing Belt (Up side)</p> <p>Manual knob</p>	14Places

						TITLE Preventive Maintenance Manual	
						DRAW. NO. P3KD02160-0002	
						CUST	
02	2008.02.25	M.NAKAO	K.KITANO	Y.KATOH	Item2 of maintenance tools changed		
EDIT	DATE	DESIG.	CHECK	APPR.	DESCRIPTION		
DESIG.	2008.02.25	M.NAKAO	CHECK	K.KITANO	APPR.	Y.KATOH	FUJITSU FRONTECH LIMITED
							14 / 31

PM-BLT-020

Flat belt (SEP/BV-Ent)

Cleaning procedure

1. Wipe and clean the whole surface on the belts with a waste cloth which applied solvent by rotating the manual knob.
2. Make sure if the belt is not coming off from the pulley.

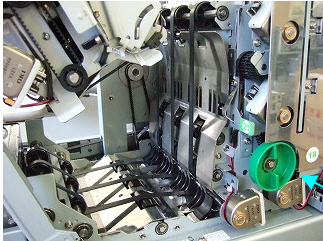
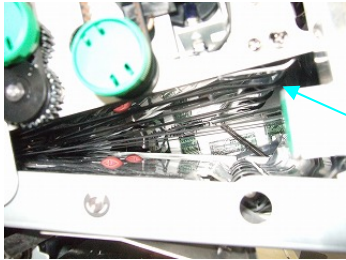
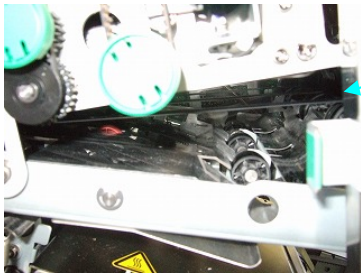
Point	Tool	Detail	Remark
Flat belt (SEP)	Waste Ethanol solvent Or Isopropyl Alcohol	 <div data-bbox="1050 869 1299 931" style="border: 1px solid black; padding: 2px;">Manual knob</div>	6Places
		 <div data-bbox="1056 1077 1308 1261" style="border: 1px solid black; padding: 2px;">Flat Belt (Up side) (3Places)</div>	
		 <div data-bbox="1066 1379 1315 1554" style="border: 1px solid black; padding: 2px;">Flat Belt (Down side) (3Places)</div>	

					TITLE Preventive Maintenance Manual	
					DRAW. NO. P3KD02160-0002	
					CUST	
02	2008.02.25	M.NAKAO	K.KITANO	Y.KATOH	Item2 of maintenance tools changed	
EDIT	DATE	DESIG.	CHECK	APPR.	DESCRIPTION	
DESIG.	2008.02.25	M.NAKAO	CHECK	K.KITANO	APPR.	Y.KATOH
FUJITSU FRONTECH LIMITED						SHEET 15 / 31

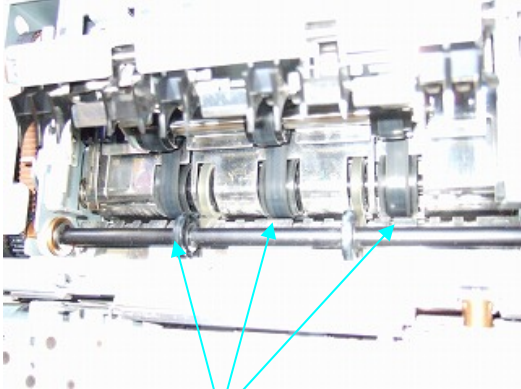
Point	Tool	Detail	Remark
Flat Belt (SEP/ BV-Ent)	Waste Ethanol solvent Or Isopropyl Alcohol	 <p data-bbox="815 819 992 898">Flat Belt</p>	3Places

						TITLE Preventive Maintenance Manual	
						DRAW. NO. P3KD02160-0002	
						CUST	
02	2008.02.25	M.NAKAO	K.KITANO	Y.KATOH	Item2 of maintenance tools changed		
EDIT	DATE	DESIG.	CHECK	APPR.	DESCRIPTION		
DESIG.	2008.02.25	M.NAKAO	CHECK	K.KITANO	APPR.	Y.KATOH	FUJITSU FRONTECH LIMITED
							16 / 31

PM-BLT-030

Flat belt (UPT)

Cleaning procedure

1. Wipe and clean the whole surface on the belts with a waste cloth which applied solvent by rotating the manual knob.
2. Make sure if the belt is not coming off from the pulley.

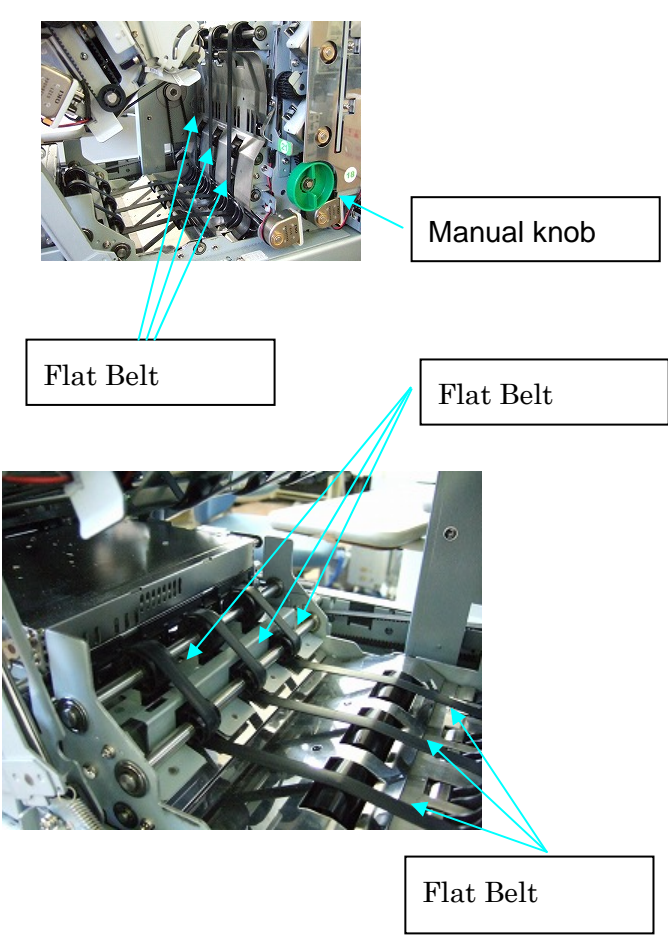
Point	Tool	Detail	Remark
Flat belt (UPT)	Waste Ethanol solvent Or Isopropyl Alcohol	 <p>Manual knob</p> <p>Flat Belt</p> <p>Flat Belt</p> <p>Flat Belt</p>	9Places

						TITLE Preventive Maintenance Manual	
						DRAW. NO. P3KD02160-0002	
02						CUST	
2008.02.25						Item2 of maintenance tools changed	
M.NAKAO							
K.KITANO							
Y.KATOH							
EDIT						DESCRIPTION	
DATE						FUJITSU FRONTECH LIMITED	
DESIG.						17 / 31	
2008.02.25						31	
M.NAKAO							
CHECK							
K.KITANO							
APPR.							
Y.KATOH							

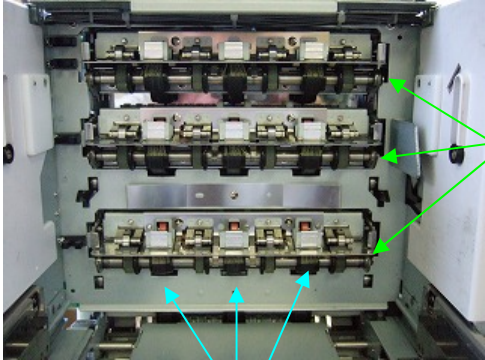
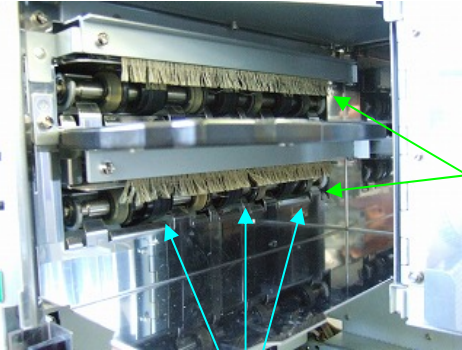
Point	Tool	Detail	Remark
Flat belt (UPT)	Waste Ethanol solvent Or Isopropyl Alcohol	<div data-bbox="646 293 920 356" style="border: 1px solid black; padding: 2px; margin-bottom: 10px;">Removable type</div>  <div data-bbox="1129 533 1315 611" style="border: 1px solid green; padding: 2px; margin-left: 100px;">3Places</div> <div data-bbox="759 801 1010 880" style="border: 1px solid black; padding: 2px; margin-left: 50px;">Flat Belt</div>	
		<div data-bbox="632 947 807 1010" style="border: 1px solid black; padding: 2px; margin-bottom: 10px;">Fix type</div>  <div data-bbox="1121 1189 1307 1267" style="border: 1px solid green; padding: 2px; margin-left: 100px;">2Places</div> <div data-bbox="767 1458 1018 1536" style="border: 1px solid black; padding: 2px; margin-left: 50px;">Flat Belt</div>	

						TITLE Preventive Maintenance Manual		
						DRAW. NO. P3KD02160-0002		
						CUST		
02	2008.02.25	M.NAKAO	K.KITANO	Y.KATOH	Item2 of maintenance tools changed			
EDIT	DATE	DESIG.	CHECK	APPR.	DESCRIPTION			
DESIG.	2008.02.25	M.NAKAO	CHECK	K.KITANO	APPR.	Y.KATOH	FUJITSU FRONTECH LIMITED	
							SHEET	18 / 31

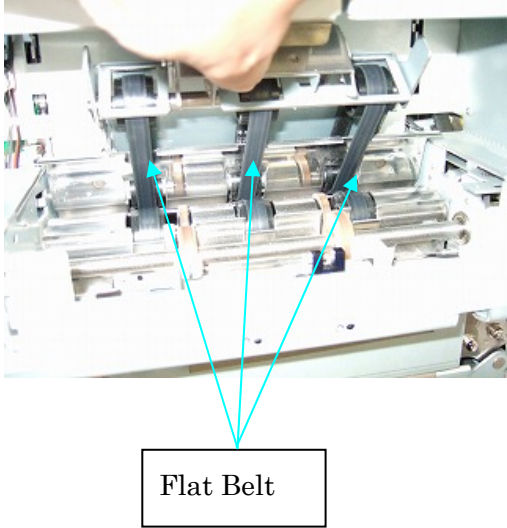
Point	Tool	Detail	Remark
Flat belt (UPT)	Waste Ethanol solvent Or Isopropyl Alcohol		

						TITLE Preventive Maintenance Manual	
						DRAW. NO. P3KD02160-0002	CUST
02	2008.02.25	M.NAKAO	K.KITANO	Y.KATOH	Item2 of maintenance tools changed		
EDIT	DATE	DESIG.	CHECK	APPR.	DESCRIPTION		
DESIG.	2008.02.25	M.NAKAO	CHECK	K.KITANO		APPR. Y.KATOH	FUJITSU FRONTECH LIMITED <small>SHEET</small> 19 / 31

PM-BLT-040

Flat belt (ESC)

Cleaning procedure

1. Wipe and clean the whole surface on the belts with a waste cloth which applied solvent .
2. Make sure if the belt is not coming off from the pulley.

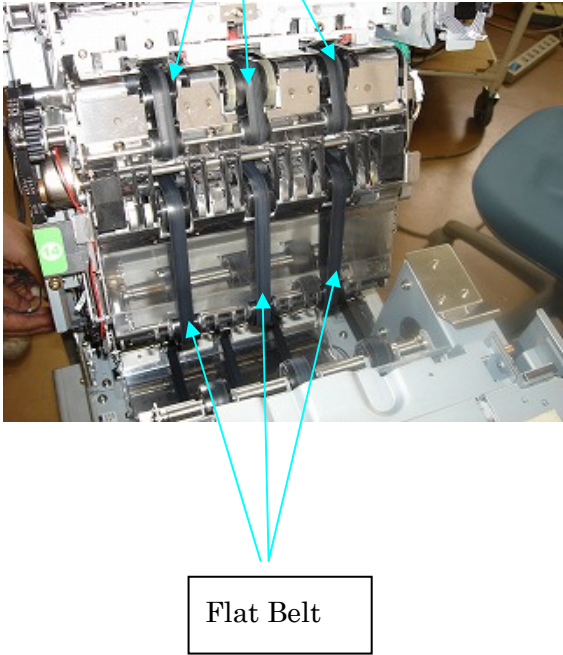
Point	Tool	Detail	Remark
Flat belt (ESC)	Waste Ethanol solvent Or Isopropyl Alcohol		6Places

						TITLE Preventive Maintenance Manual	
						DRAW. NO. P3KD02160-0002	
						CUST	
02	2008.02.25	M.NAKAO	K.KITANO	Y.KATOH	Item2 of maintenance tools changed		
EDIT	DATE	DESIG.	CHECK	APPR.	DESCRIPTION		
DESIG.	2008.02.25	M.NAKAO	CHECK	K.KITANO	APPR.	Y.KATOH	FUJITSU FRONTECH LIMITED SHEET 20 / 31

PM-BLT-050

Flat belt (LWT)

Cleaning procedure

1. Wipe and clean the whole surface on the belts with a waste cloth which applied solvent .
2. Make sure if the belt is not coming off from the pulley.

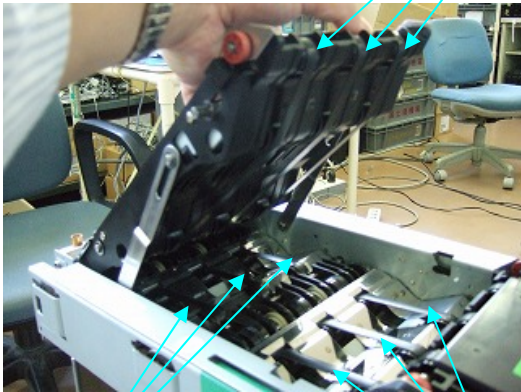
Point	Tool	Detail	Remark
Flat belt (LWT)	Waste Ethanol solvent Or Isopropyl Alcohol	For Cassette 3/4 	9Places

						TITLE Preventive Maintenance Manual	
						DRAW. NO. P3KD02160-0002	
02	2008.02.25	M.NAKAO	K.KITANO	Y.KATOH	Item2 of maintenance tools changed	CUST	
EDIT	DATE	DESIG.	CHECK	APPR.	DESCRIPTION	FUJITSU FRONTECH LIMITED	
DESIG.	2008.02.25	M.NAKAO	CHECK	K.KITANO	APPR.	Y.KATOH	21 / 31

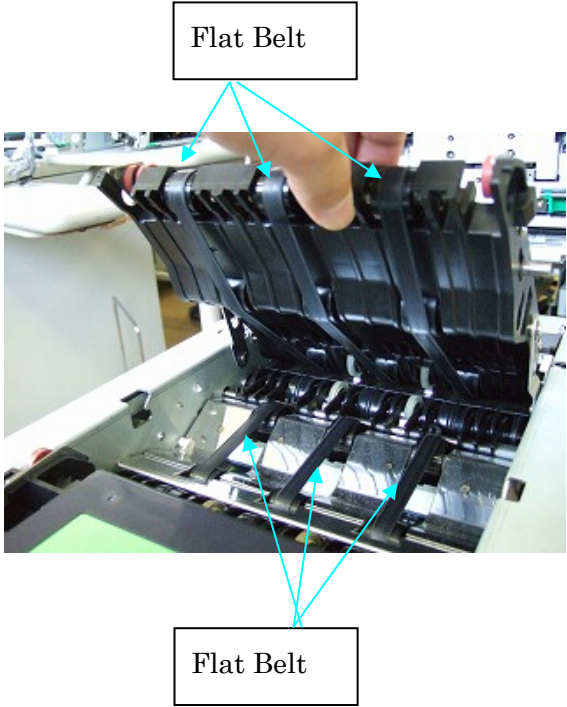
Point	Tool	Detail	Remark
Flat belt (LWT)	Waste Ethanol solvent Or Isopropyl Alcohol	For Cassette 1/2 	6Places

					TITLE Preventive Maintenance Manual	
					DRAW. NO. P3KD02160-0002	
					CUST	
02	2008.02.25	M.NAKAO	K.KITANO	Y.KATOH	Item2 of maintenance tools changed	
EDIT	DATE	DESIG.	CHECK	APPR.	DESCRIPTION	
DESIG.	2008.02.25	M.NAKAO	CHECK	K.KITANO	APPR.	Y.KATOH
FUJITSU FRONTECH LIMITED						22 / 31

PM-RLL-010

Roller (SEP/BV-Ent)

Cleaning procedure

1. Wipe and clean the whole surface on the rollers with a waste cloth which applied solvent by rotating the manual knob.

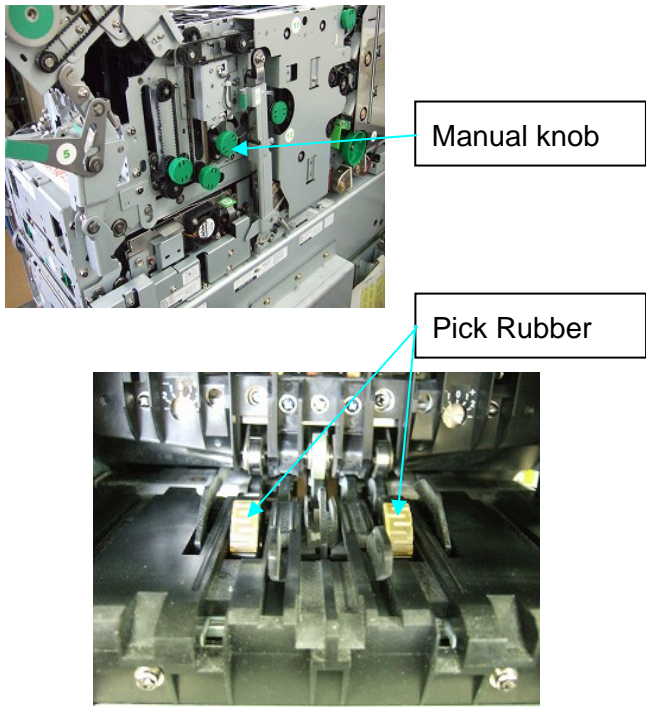
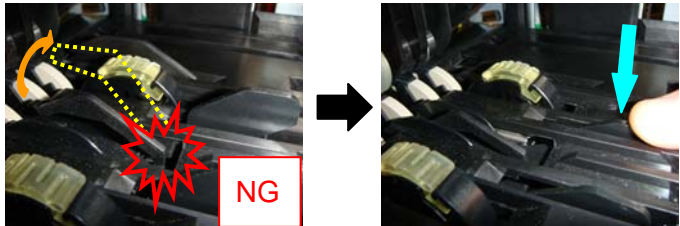
Point	Tool	Detail	Remark
Roller (SEP)	Waste Ethanol solvent Or Isopropyl Alcohol	 <p>Manual knob</p> <p>Pick Rubber</p>	
		<p>Note) Do not damage the lever hanging the tip of the lever. Do while lowering this lever (blue arrow).</p> 	

						TITLE Preventive Maintenance Manual	
						DRAW. NO. P3KD02160-0002	
02						CUST	
2008.02.25						Item2 of maintenance tools changed	
M.NAKAO		K.KITANO		Y.KATOH			
EDIT	DATE	DESIG.	CHECK	APPR.	DESCRIPTION		
DESIG.	2008.02.25	M.NAKAO	CHECK	K.KITANO	APPR.	Y.KATOH	FUJITSU FRONTECH LIMITED
							23 / 31

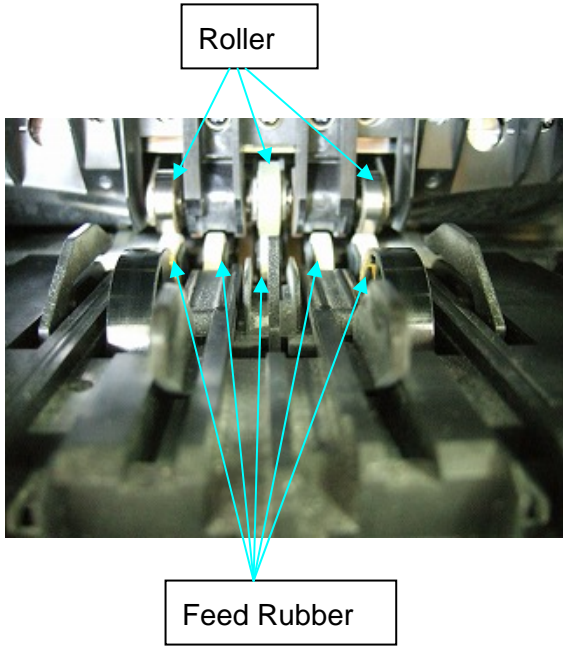
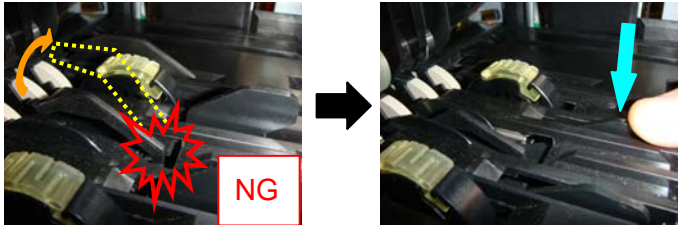
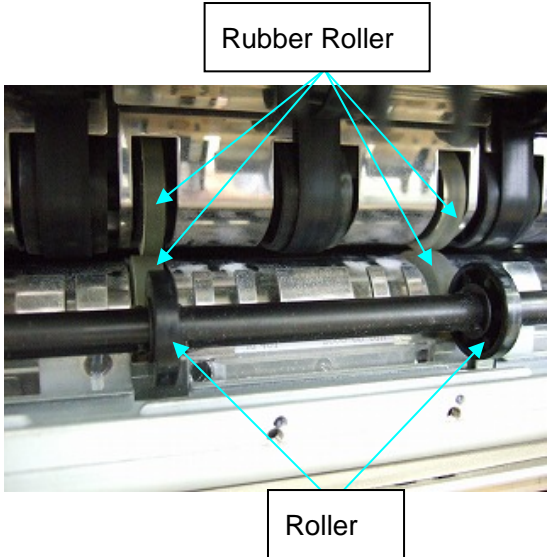
Point	Tool	Detail	Remark
Roller (SEP)	Waste Ethanol solvent Or Isopropyl Alcohol		
		<p>Note) Do not damage the lever hanging the tip of the lever. Do while lowering this lever (blue arrow).</p> 	
(SEP/ BV-Ent)	Waste Ethanol solvent or Isopropyl Alcohol		

						TITLE Preventive Maintenance Manual	
						DRAW. NO. P3KD02160-0002	
02	2008.02.25	M.NAKAO	K.KITANO	Y.KATOH	Item2 of maintenance tools changed		CUST
EDIT	DATE	DESIG.	CHECK	APPR.	DESCRIPTION		SHEET 24 / 31
DESIG.	2008.02.25	M.NAKAO	CHECK	K.KITANO	APPR.	Y.KATOH	
						FUJITSU FRONTECH LIMITED	

PM-RLL-020

Roller (UPT)

Cleaning procedure

1. Wipe and clean the whole surface on the rollers with a waste cloth which applied solvent by rotating the manual knob.

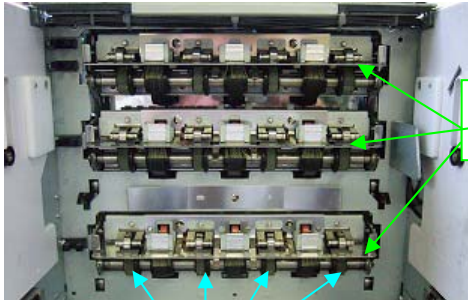
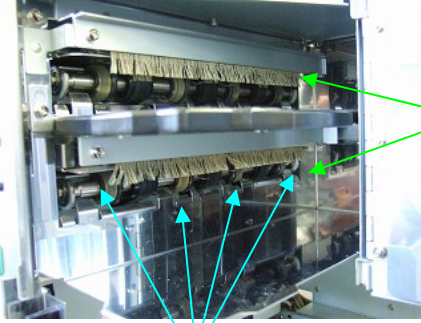
Point	Tool	Detail	Remark
Roller (UPT)	Waste Ethanol solvent Or Isopropyl Alcohol	<div style="text-align: center;"> <div data-bbox="639 674 914 741" style="border: 1px solid black; padding: 2px;">Removable type</div>  <div data-bbox="1129 835 1310 913" style="border: 1px solid green; padding: 2px;">3Places</div> <div data-bbox="807 1106 954 1184" style="border: 1px solid black; padding: 2px;">Roller</div> <div data-bbox="632 1205 807 1272" style="border: 1px solid black; padding: 2px;">Fix type</div>  <div data-bbox="1129 1361 1315 1440" style="border: 1px solid green; padding: 2px;">2Places</div> <div data-bbox="807 1666 954 1744" style="border: 1px solid black; padding: 2px;">Roller</div> </div>	

					TITLE Preventive Maintenance Manual	
					DRAW. NO. P3KD02160-0002	
					CUST	
02	2008.02.25	M.NAKAO	K.KITANO	Y.KATOH	Item2 of maintenance tools changed	
EDIT	DATE	DESIG.	CHECK	APPR.	DESCRIPTION	
DESIG.	2008.02.25	M.NAKAO	CHECK	K.KITANO	APPR.	Y.KATOH
FUJITSU FRONTECH LIMITED						SHEET 25 / 31

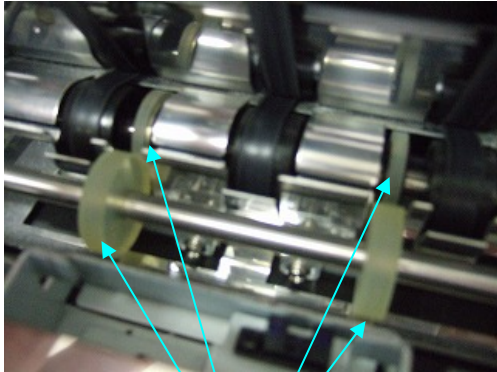
Point	Tool	Detail	Remark
Roller (UPT)	Waste Ethanol solvent Or Isopropyl Alcohol	 <div data-bbox="876 752 1023 831" style="border: 1px solid black; padding: 2px; display: inline-block;">Roller</div>	

					TITLE Preventive Maintenance Manual	
					DRAW. NO. P3KD02160-0002	
					CUST	
02	2008.02.25	M.NAKAO	K.KITANO	Y.KATOH	Item2 of maintenance tools changed	
EDIT	DATE	DESIG.	CHECK	APPR.	DESCRIPTION	
DESIG.	2008.02.25	M.NAKAO	CHECK	K.KITANO	APPR.	Y.KATOH
FUJITSU FRONTECH LIMITED						26 / 31

PM-RLL-030

Roller (ESC)

Cleaning procedure

1. Wipe and clean the whole surface on the rollers with a waste cloth which applied solvent .

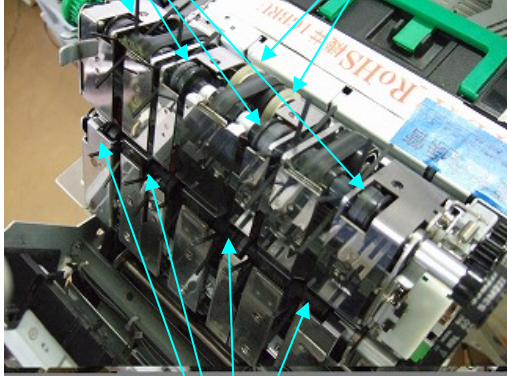
Point	Tool	Detail	Remark
Roller (ESC)	Waste Ethanol solvent Or Isopropyl Alcohol		

						TITLE Preventive Maintenance Manual	
						DRAW. NO. P3KD02160-0002	
						CUST	
02	2008.02.25	M.NAKAO	K.KITANO	Y.KATOH	Item2 of maintenance tools changed		
EDIT	DATE	DESIG.	CHECK	APPR.	DESCRIPTION		
DESIG.	2008.02.25	M.NAKAO	CHECK	K.KITANO	APPR.	Y.KATOH	FUJITSU FRONTECH LIMITED
							27 / 31

PM-RLL-040

Roller (LWT)

Cleaning procedure

1. Wipe and clean the whole surface on the rollers with a waste cloth which applied solvent .

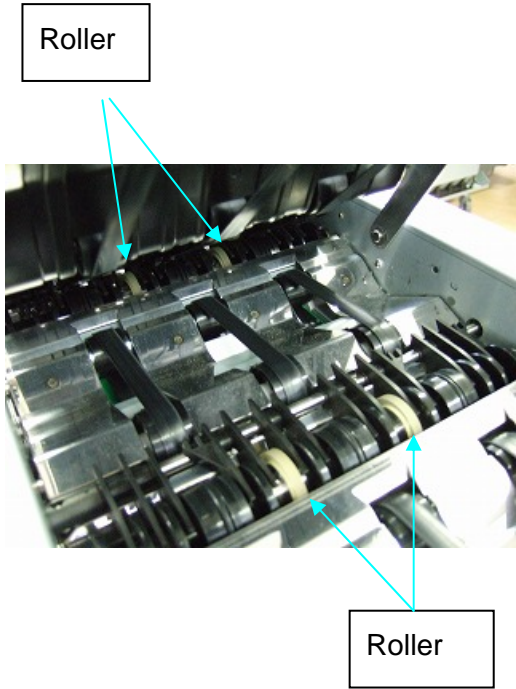
Point	Tool	Detail	Remark
Roller (LWT)	Waste Ethanol solvent Or Isopropyl Alcohol	<p>For Cassette 3/4</p> 	

						TITLE Preventive Maintenance Manual	
						DRAW. NO. P3KD02160-0002	
						CUST	
02	2008.02.25	M.NAKAO	K.KITANO	Y.KATOH	Item2 of maintenance tools changed		
EDIT	DATE	DESIG.	CHECK	APPR.	DESCRIPTION		
DESIG.	2008.02.25	M.NAKAO	CHECK	K.KITANO	APPR.	Y.KATOH	FUJITSU FRONTECH LIMITED
							28 / 31

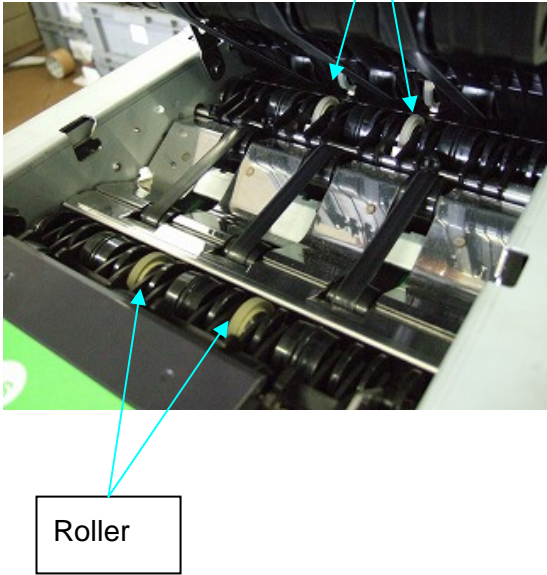
Point	Tool	Detail	Remark
Roller (LWT)	Waste Ethanol solvent Or Isopropyl Alcohol	For Cassette 1/2 	

					TITLE Preventive Maintenance Manual	
					DRAW. NO. P3KD02160-0002	
02	2008.02.25	M.NAKAO	K.KITANO	Y.KATOH	Item2 of maintenance tools changed	CUST
EDIT	DATE	DESIG.	CHECK	APPR.	DESCRIPTION	
DESIG.	2008.02.25	M.NAKAO	CHECK	K.KITANO	APPR. Y.KATOH	FUJITSU FRONTECH LIMITED SHEET 29 / 31

PM-RLL-050

Roller (CAS)

Cleaning procedure

1. Wipe and clean the whole surface on the rollers with a waste cloth which applied solvent .

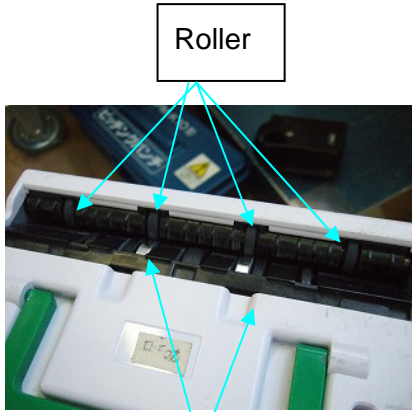
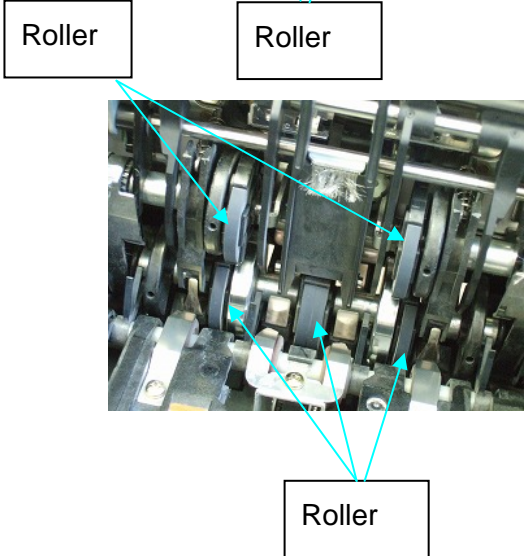
Point	Tool	Detail	Remark
Roller (CAS)	Waste Ethanol solvent Or Isopropyl Alcohol	<p>For recycle Cassette</p>  	

						TITLE Preventive Maintenance Manual	
						DRAW. NO. P3KD02160-0002	
						CUST	
02	2008.02.25	M.NAKAO	K.KITANO	Y.KATOH	Item2 of maintenance tools changed		
EDIT	DATE	DESIG.	CHECK	APPR.	DESCRIPTION		
DESIG.	2008.02.25	M.NAKAO	CHECK	K.KITANO	APPR.	Y.KATOH	FUJITSU FRONTECH LIMITED
							30 / 31

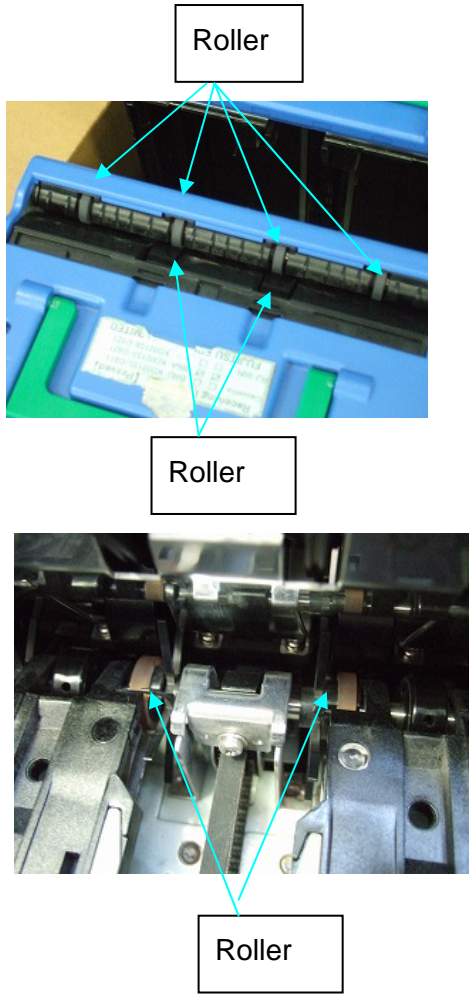
Point	Tool	Detail	Remark
Roller (CAS)	Waste Ethanol solvent Or Isopropyl Alcohol	<p>For deposit Cassette</p> 	

					TITLE Preventive Maintenance Manual	
					DRAW. NO. P3KD02160-0002	
					CUST	
02	2008.02.25	M.NAKAO	K.KITANO	Y.KATOH	Item2 of maintenance tools changed	
EDIT	DATE	DESIG.	CHECK	APPR.	DESCRIPTION	
DESIG.	2008.02.25	M.NAKAO	CHECK	K.KITANO	APPR.	Y.KATOH
					FUJITSU FRONTECH LIMITED	
					31 / 31	